

USER'S MANUAL

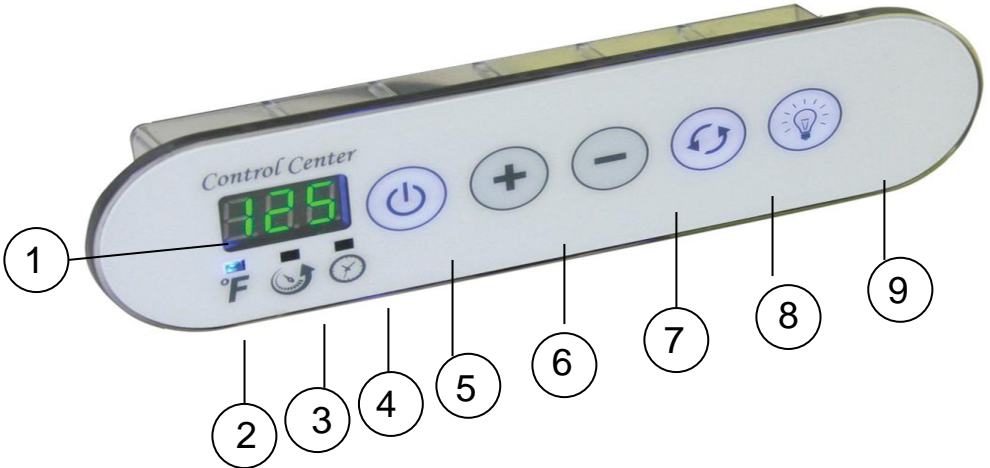

5-Button Control Keypad with Temperature Display for VSC/BSC



Understanding the Unit

1	Display	SCREEN OFF: Unit is in 'idle' mode
		SCREEN ON: Unit is displaying temperature, speed, time remaining or error information.
2	Temperature in °F	When on, the screen displays temperature value in °F
3	Speed level	When on, the screen displays speed level from 1 to 10
4	Time remaining	When on, the screen displays the time remaining in minutes
5	Power button	1 st press: Pump ON, Light ON, LED ON
		2 nd press: Pump OFF, Light OFF, LED OFF, Display Idle
6	Speed + button	Speed goes up, screen displays speed. Max. speed level is 10.
7	Speed – button	Speed goes down, screen displays speed. Min. speed level is 1.
8	Pulse mode button	1 st press: Pulse mode ON, LED ON
		2 nd press: Pulse mode OFF, LED OFF
9	Light button	1 st press: Light ON, LED ON
		2 nd press: Light OFF, LED OFF

Features

- Pulsating Mode:** In this mode, the pump speed varies automatically with a cycle period of approximately 10 seconds.
- By default, the pump speed level is set to 10. When the pump is turned OFF, the speed level at the time of turning OFF is saved.

- When the pump is turned ON, the pump speed is softly ramped up to maximum speed in about 5 seconds, and then the pump speed goes back to saved speed level/ default level. During the 5 second soft ramp up, the 'Speed+', 'Speed-' and 'Pulse' mode buttons are disabled.
- The unit has 20-minute built-in timer. The unit will shut down after 20 minutes of operation and save the speed level for next cycle use.

Note: Make sure that the water level sensor or a jumper is connected to VSC box. Otherwise, the unit will not turn on.

Error Codes

The display screen has special error codes to determine and debug possible error conditions. They are as follows:

E-1	There is a connection problem between VSC/BSC to keypad. The power button LED also blinks 'fast' to indicate the connection error. Try reconnecting the cable and reset the power on VSC/BSC.
NC	The temperature probe on the back of keypad is not connected. Try re-connecting probe again.
LO	Temperature value is Below 50 °F
HI	Temperature value is Above 140 °F
No H2O	The power button LED also blinks 'slowly' to indicate this error. The unit will not turn on because the water level sensor is detecting no water in tub. If water level sensor is not used, a jumper should be connected at water sensor port of VSC/BSC.
E-2	The unit shuts down due to over-heating. Check the fan connection in the VSC unit.

Understanding the Setup

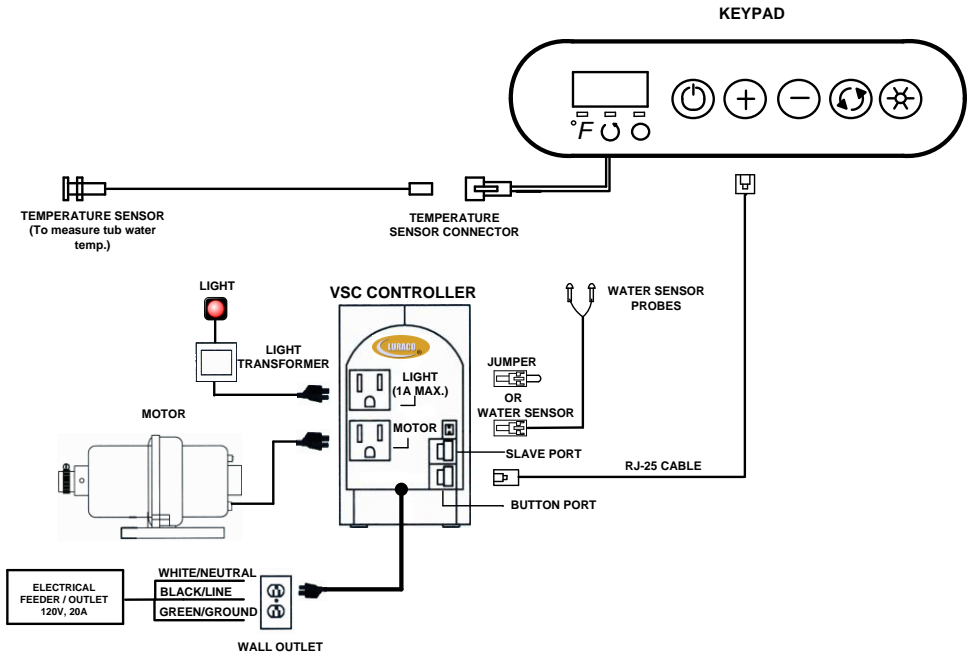

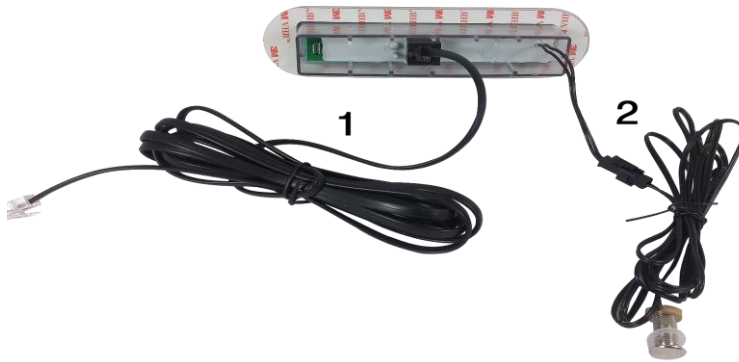

1	RJ25 Cable	Connect one end to the back of keypad and the other end to the 'button' port of VSC/BSC.
2	Temperature Probe	Connect the square female end of the probe to the male end of the keypad. Drop the probe onto water.

Steps to Follow

1. Connect keypad to VSC/BSC using RJ25 cable.
2. Connect the temperature probe on the back of keypad.
3. Connect water level sensor/ jumper on the sensor port of VSC/BSC.
4. Connect Pump to the 'Pump outlet' and Light to the 'Light outlet' of the VSC/BSC.
5. Connect power cable to the power outlet and turn on the unit using power button on keypad.

2D Drawing

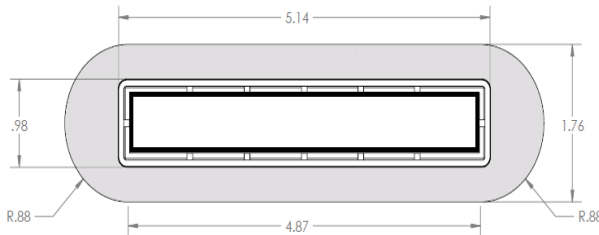

Backside view of keypad (All dimensions in inch)

WARRANTY INFORMATION

One (1) YEAR LIMITED WARRANTY

1. This Warranty applies only to the original purchaser of this product.
2. This Warranty applies ONLY to repair or replacement of any supplied or manufactured parts of this product. The warranty does not cover normal wear, coating, dropped or abused units.
3. Unless otherwise proscribed by law, LURACO shall not be liable for any personal injury, property or any incidental or consequential damages of any kind resulting from malfunctions, defects, misuse, improper installation or alteration of this product.

Attention: Any modification to the product will void the warranty

Important Instructions

If you need to send a unit to us for repair, please follow the steps below.

1. Carefully pack the item in its original carton or other suitable box to avoid damage in shipping.
2. Before packing your unit; be sure to enclose:
 - Your name with full shipping address and telephone number
 - A dated receipt for PROOF OF PURCHASE
 - Include a detailed description of the problem you are having

Disclaimers

Limited warranty and liability — Information in this document is believed to be accurate and reliable. However, LURACO Health & Beauty, LLC does not give any representations or warranties, expressed or implied, as to the accuracy or completeness of such information and shall have no liability for the consequences of use of such information.

In no event shall LURACO Health & Beauty, LLC be liable for any indirect, incidental, punitive, special or consequential damages (including - without limitation - lost profits, lost savings, business interruption, costs related to the removal or replacement of any products or rework charges) whether or not such damages are based on tort (including negligence), warranty, breach of contract or any other legal theory.

Notwithstanding any damages that customer might incur for any reason whatsoever, LURACO Health & Beauty, LLC' aggregate and cumulative liability towards customer for the products described herein shall be limited in accordance with the Terms and Conditions of commercial sale of LURACO Health & Beauty, LLC.

Right to make changes — LURACO Health & Beauty, LLC reserves the right to make changes to the product and information published in this document, including without limitation specifications and product descriptions, at any time and without notice. This document supersedes and replaces all information supplied prior to the publication hereof.

Suitability for use — LURACO Health & Beauty, LLC products are not designed, authorized or warranted to be suitable for use in life support, life-critical or safety-critical systems or equipment, nor in applications where failure or malfunction of an LURACO Health & Beauty, LLC' product can reasonably be expected to result in personal injury, death or severe property or environmental damage.

THANK YOU FOR BUYING LURACO PRODUCTS



LURACO HEALTH & BEAUTY, LLC
1140 107TH STREET, ARLINGTON, TX 76011
TEL: +1-817-633-1080, FAX: +1-817-633-1085
WWW.LURACO.COM